

BFL 2011

for generator sets

12 - 46 kW | 15 - 62 hp at 1500/1800 min⁻¹ | rpm

EU Stage II / US EPA Tier 2

- Oil-cooled 2, 3 and 4-cylinder aspirated engine in inline construction with integrated cooling system.
- 4-cylinder also with turbocharging.
- Direct injection with single injection pumps and optional electronic governor.
- Low fuel consumption due to optimised combustion.

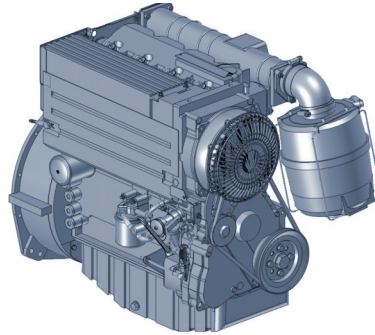

- Long oil change intervals of up to 1000 hours.
- Minimised running costs due to low maintenance need and little wear.
- High reliability combined with durability. No corrosion or cavitation due to oil cooling and lubrication.
- A very good load response ensures an immediate power supply.

Technical data

Engine type		F2L 2011	F3L 2011	F4L 2011	BF4L 2011
No. of cylinders		2	3	4	4
Bore/stroke	mm in	94/112 3.7/4.4	94/112 3.7/4.4	94/112 3.7/4.4	94/112 3.7/4.4
Displacement	l cu in	1.6 95	2.3 142	3.1 190	3.1 190
Weight (incl. cooler and fan)	kg lb	212 468	254 560	293 646	295 649
Governing standard ¹⁾		G2	G2	G2	G2

50 Hz / 1500 min⁻¹

Power		F2L 2011	F3L 2011	F4L 2011	BF4L 2011
Continuous Power (COP) ²⁾	kW hp	11.5 15.4	18.1 24.3	26.4 35.4	34.8 46.7
Prime Power (PRP) ³⁾	kW hp	12.1 16.2	19.1 25.6	27.8 37.3	36.6 49.1
Limited Time Power (LTP) ⁴⁾	kW hp	12.7 17.0	20.1 27.0	29.1 39.2	38.4 51.5
Fan power consumption	kW hp	0.1 0.1	0.1 0.1	0.2 0.2	0.3 0.3
Typical Generator Output COP ⁵⁾	kVA	13	20	30	39
Typical Generator Output PRP ⁵⁾	kVA	13	21	31	41
Typical Generator Output LTP ⁵⁾	kVA	14	22	33	43

60 Hz / 1800 min⁻¹

Power		F2L 2011	F3L 2011	F4L 2011	BF4L 2011
Continuous Power (COP) ²⁾	kW hp	13.7 18.4	21.6 29.0	31.4 42.1	41.4 55.5
Prime Power (PRP) ³⁾	kW hp	14.4 19.3	22.7 30.4	33.1 44.4	43.6 58.5
Limited Time Power (LTP) ⁴⁾	kW hp	15.2 20.4	23.9 32.1	34.8 46.7	45.9 61.6
Fan power consumption	kW hp	0.1 0.1	0.1 0.1	0.3 0.3	0.4 0.4
Typical Generator Output COP ⁵⁾	kWe	12	19	28	37
Typical Generator Output PRP ⁵⁾	kWe	13	21	30	39
Typical Generator Output LTP ⁵⁾	kWe	13	22	31	41

1) According to ISO 8528-5.

2) Continuous Power: No time limitation, plus 10% additional power for governing purpose only.

3) Prime Power: Average power output ≤ 80%, no time limitation, plus 5% additional power for governing purpose only.

4) Limited Time Running Power: For up to 500 h/year, thereof a maximum of 300 h/year continuous running.

5) In consideration of a generator efficiency level of 89 - 90 % and a power factor of 0.8.

The data on this data sheet are for information purposes only and are not binding values. The data in the quotation is definitive.

The engine company.



50 Hz / 1500 min⁻¹

Fuel Consumption (PRP) ¹⁾		F2L 2011	F3L 2011	F4L 2011	BF4L 2011
Fuel consumption 25% load	g/kWh lb/hph	301 0.49	299 0.49	264 0.43	259 0.43
Fuel consumption 50% load	g/kWh lb/hph	246 0.40	236 0.39	226 0.37	223 0.37
Fuel consumption 75% load	g/kWh lb/hph	235 0.39	224 0.37	216 0.36	226 0.37
Fuel consumption 100% load	g/kWh lb/hph	244 0.40	233 0.38	222 0.36	237 0.39

Heat balance & cooling system		F2L 2011	F3L 2011	F4L 2011	BF4L 2011
Heat dissipation (engine radiator) ²⁾	kW hp	-	-	-	-
Heat dissipation (convection)	kW hp	-	-	-	-
Cooling air flow	m ³ /h cfm	1065 627	1075 633	1490 877	1885 1109

Inlet & exhaust data		F2L 2011	F3L 2011	F4L 2011	BF4L 2011
max. intake depression	mbar psi	20 0.29	20 0.29	20 0.29	20 0.29
Combustion air volume	m ³ /h cfm	61 36	86 51	122 72	160 94
max. exhaust gas temperature	°C °F	510 950	510 950	510 950	600 1112
Exhaust gas flow	m ³ /h cfm	169 99	236 139	337 198	445 262

60 Hz / 1800 min⁻¹

Fuel Consumption (PRP) ¹⁾		F2L 2011	F3L 2011	F4L 2011	BF4L 2011
Fuel consumption 25% load	g/kWh lb/hph	304 0.50	294 0.48	280 0.46	265 0.44
Fuel consumption 50% load	g/kWh lb/hph	249 0.41	237 0.39	230 0.38	221 0.36
Fuel consumption 75% load	g/kWh lb/hph	237 0.39	225 0.37	220 0.36	219 0.36
Fuel consumption 100% load	g/kWh lb/hph	245 0.40	236 0.39	230 0.38	224 0.37

Heat balance & cooling system		F2L 2011	F3L 2011	F4L 2011	BF4L 2011
Heat dissipation (engine radiator) ²⁾	kW hp	-	-	-	-
Heat dissipation (convection)	kW hp	2.5 3.4	3.4 4.6	5.0 6.7	6.5 8.7
Cooling air flow	m ³ /h cfm	1275 750	1290 759	1790 1054	2265 1333

Inlet & exhaust data		F2L 2011	F3L 2011	F4L 2011	BF4L 2011
max. intake depression	mbar psi	20 0.29	20 0.29	20 0.29	20 0.29
Combustion air volume	m ³ /h cfm	68 40	104 61	137 81	191 112
max. exhaust gas temperature	°C °F	510 950	520 968	540 1004	560 1040
Exhaust gas flow	m ³ /h cfm	199 117	295 174	400 235	531 313

1) Refers to diesel with a density of 0.835 kg/dm³ at 15°C | 6.96 lb/US gallon at 60°F.

2) The heat quantities are valid for the dimensioning of the cooling system.

Dimensions

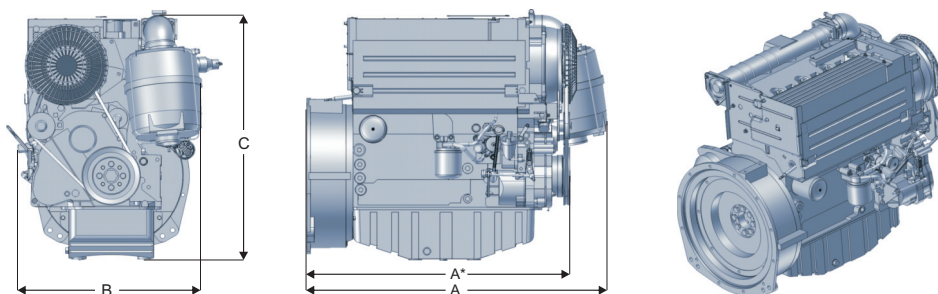

		A	A*	B	C
F2L 2011	mm in	645 25	540 21	590 23	705 28
F3L 2011	mm in	755 30	650 26	590 23	700 28
F4L 2011	mm in	870 34	760 30	590 23	720 28
BF4L 2011	mm in	-	780 31	530 21	705 28

Note: The engine dimensions and weights vary depending on the scope of delivery.

For more information please contact the DEUTZ AG Köln or the responsible sales partner.

